



DC30 Nuvia

Product guide

Table of Contents

| | |
|---|----|
| Introduction..... | 4 |
| 1. Safety instructions and warranty disclaimer | 5 |
| 1.1 Disclaimer | 5 |
| 1.2 Explanation of safety icons and instructions..... | 6 |
| 2. Product overview | 7 |
| 2.1 Exterior | 7 |
| 2.2 Details..... | 8 |
| 2.3 Interior | 9 |
| 2.4 Included with the charger | 10 |
| 3. Preparation of installation site | 11 |
| 3.1 Site selection | 11 |
| 3.2 Equipment | 11 |
| 3.3 Power connections..... | 11 |
| 3.3.1 Star connection | 12 |
| 3.3.2 Branch sleeve connection | 12 |
| 3.4 Communication infrastructure | 12 |
| 3.4.1 GSM connection | 13 |
| 3.4.2 LAN connection..... | 13 |
| 4. Installation | 14 |
| 4.1 Ground mounting with stand | 14 |
| 4.1.1 Stand with foundation; ground pin | 14 |
| 4.1.2 Stand without foundation; Baseplate | 16 |
| 4.2 Wall mounting | 17 |
| 4.3 Electrical installation | 19 |
| 5. Commissioning | 20 |
| 5.1 Initial startup | 20 |
| 5.2 Activating charger | 20 |
| 5.3 Testing charger | 21 |
| 6. Configuration | 22 |
| 7. Charging methods | 25 |
| 7.1 RFID | 25 |
| 7.2 Plug & Charge ISO15118* | 25 |
| 7.3 Dynamic QR-Code* | 25 |
| 8. Care and maintenance | 26 |

| | |
|--|----|
| 9. Troubleshooting & Support | 27 |
| 9.1 Requesting support..... | 27 |
| 9.2 Charger status and LED indications | 27 |
| 10. Legal..... | 28 |
| 10.1 CE Declaration..... | 28 |
| 10.2 WEEE | 28 |
| 10.3 Warranty | 28 |
| 10.4 Returns | 28 |
| 11. Appendix..... | 29 |
| I Technical specifications | 29 |
| II Product dimensions | 32 |
| III Dimensions Stand..... | 33 |
| IV Dimensions Stand baseplate | 34 |
| V Drill instructions mounting plate | 35 |

Introduction

This manual applies to the Ecotap DC30 Nuvia, produced by Ecotap B.V., Kruisbroeksestraat 23, 5281 RV Boxtel, The Netherlands. The DC30 Nuvia is intended solely for charging electric vehicles. Use this manual to ensure proper installation and commissioning.

All installation, commissioning, and maintenance work must be carried out by a qualified electrician, who must comply with NEN1010 and NEN3140 or country equivalent.

This document has undergone technical review and is updated regularly. Although Ecotap strives to keep the information accurate and current, the company accepts no liability for any damage or issues arising from the use of this manual.

This product guide is intended for a standard installation. For more information on installations with Plaza-grid, Load balancing and Energy management systems, refer to the relevant guides on ecotap.zendesk.com.

The Ecotap B.V. general terms and conditions apply.



1. Safety instructions and warranty disclaimer

Safety is essential for both Ecotap and our installers. High power flows through our charging products, which can be dangerous if handled incorrectly. Therefore, installation and maintenance must be performed according to the proper safety standards.

1.1 Disclaimer

Please read these instructions carefully before installing the charger and keep them ready for future reference.









- Installation and service must be performed by qualified personnel only. (NEN3140)
- Always disconnect the main power supply before installation, maintenance, or repair.
- Ensure the charger is properly grounded according to NEN 1010 and IEC 61851 standards.
- Follow all local and national wiring regulations.
- Perform a last-minute-risk-analysis before working on Ecotap products.
- Do not modify or bypass any features.
- Never touch live parts. Risk of severe injury or death.
- Make sure the power network matches charger specifications.
- Avoid sharp bends or tension on charging cables.
- Do not install or operate in standing water or during heavy rain without proper protection.
- Do not install near flammable materials, explosive gases, or heat sources.
- Do not insert objects into connectors or openings.
- Do not clean with high-pressure water jets.
- Do not operate outside the specified temperature range (-25 °C to +50 °C).
- Do not use if cables or connectors are damaged.
- Do not use extension cords or adapters.

This installation guide is provided for informational purposes only. Ecotap B.V. assumes no liability for any damage, injury, or loss resulting from failure in case of:

- Failure to comply with this manual or operating conditions.
- Improper use or abuse.
- External damage or environmental conditions outside specifications.
- Installation, commissioning, or repair by unqualified persons.
- Unauthorized modifications, customizations, or configuration changes.
- Use of non-approved spare parts or accessories.
- Failures caused by grid issues, connectivity providers, or back-office systems.
- Situations beyond Ecotap's control (force majeure).
- Damage to the electrical vehicle during charging.

This document was originally written in English.

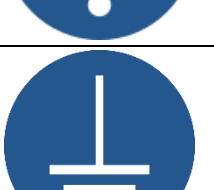
1.2 Explanation of safety icons and instructions

| Safety symbols description | |
|---|---|
| Symbol | Description |
|  | Caution: Dangerous situation that can result in human injury or death. |
|  | Attention: Dangerous situation that can result in material damage. |
|  | Disconnect power and check voltages to make sure the charger is not live. |
|  | Wear insulated gloves. |
|  | More than one person needed. |
|  | Important information. |
|  | Ground |
|  | High voltage |

2. Product overview

2.1 Exterior

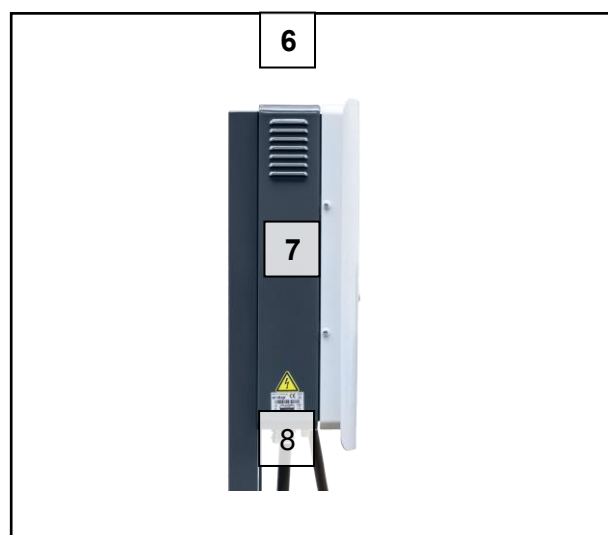
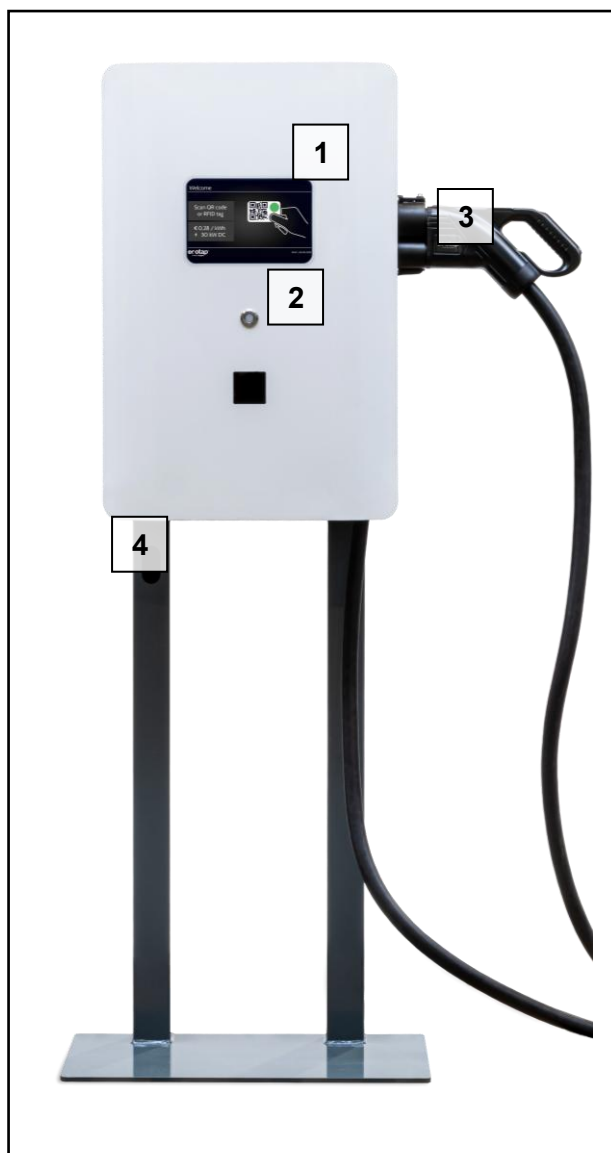

| No. | Part | Function |
|-----|------------------------|--|
| 1 | Display | User interface displaying information about charging session. |
| 2 | LED indicator | Red, green, and blue LED communicate the charger status. |
| 3 | Charging cable | Cable that goes into the EV. |
| 4 | Power input | Power input from grid to charger. |
| 5 | Cable holder | Holds cable when not in use. Press button to release connector. |
| 6 | Antenna | For communication over GSM. |
| 7 | Lock | Charger opens here for maintenance. Check maintenance guide for instruction. DC30 Nuvia opens with security Torx, not a key. |
| 8 | Identification sticker | Sticker contains serial number and other important information about the product. |

2.2 Details

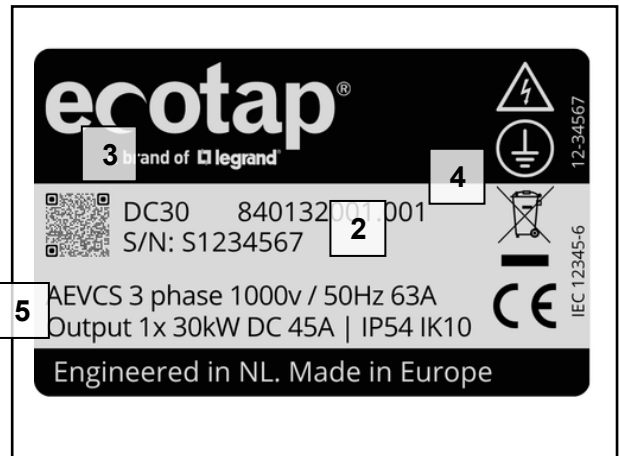
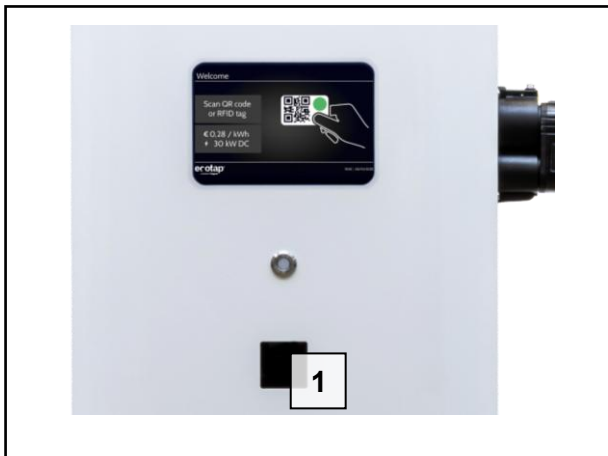

| No. | Part | Function |
|-----|------------------------|--|
| 1 | RFID reader | Receives signal from charging tag to start or end session. |
| 2 | Serial number | Unique number that indicates that specific charger. |
| 3 | Product type | The product name of your Ecotap charger. |
| 4 | ArticleNr. | Number that indicates specific type of charger. |
| 5 | Charger specifications | States power specifications, charger output, and physical protection values. |

2.3 Interior

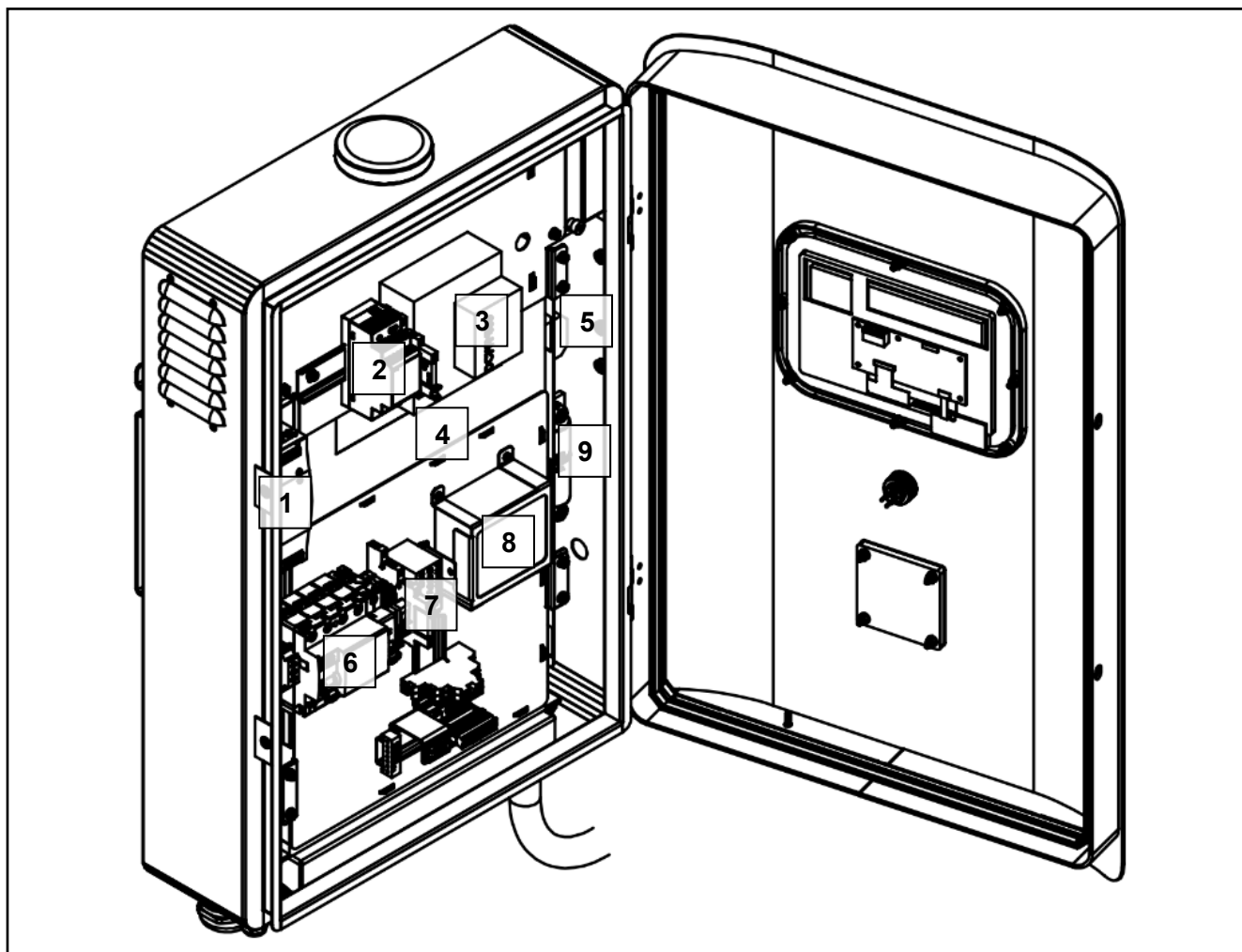

| No. | Part | Function |
|-----|------------------------------|--|
| 1 | Power supply 1 | Supplies power to auxiliary power circuit. |
| 2 | Power supply 2 | Supplies secondary power to the high voltage DC contactor. |
| 3 | Insulation Monitoring Device | Monitors isolation to detect dangerous earth faults. |
| 4 | DC Power supply unit | Generates DC power that goes into the vehicle. Is located behind safety components, accessible from the bottom. |
| 5 | High voltage DC Contactor | Completes the high-voltage DC circuits. |
| 6 | Residual current device | Detects leakage current to earth and disconnects power for safety. |
| 7 | Miniature Circuit breaker | Protects the 12V circuit during overcurrent or short circuits. |
| 8 | ECC Controller | Computer that manages charger. Has USB-C port to access charger setup dashboard. |
| 9 | DC High-speed fuse | Protects charger from short-circuits and overcurrent. |
| | MID-energy meter | Optional accessory, measures the DC power throughput with certified accuracy. Located: to the right of the IMD. |

2.4 Included with the charger

- Charger
- Mounting plate
- Mounting brackets
- Strain relief
- Hardware
- Plugs

Separate/optional accessories (not included):

- Stand, baseplate Article number: 669993
- Stand, ground pin Article number: 669992

3. Preparation of installation site

3.1 Site selection

Choosing the right location for the charger is essential for safety, performance, and user convenience. In addition to all applicable local regulations, it is crucial to consider the following:

- Make sure the site is easily accessible for vehicles and allows safe manoeuvring.
- Follow local regulations regarding placement on sidewalks, fire exits and escape routes.
- Avoid areas prone to flooding, excessive dust, or corrosive environments. Ensure the operating temperature range is according to specification: -25°C to +50°C.
- Maintain sufficient space around the charger for ventilation, maintenance, and safe cable handling. We recommend a clear space of 1m around the charger.
- Make sure the placement site is near a power distribution point, minimizing the cable length needed.
- Check your power connection to see if there is a 3-phase connection for the charger.
- We recommend using a foundation for the most durable installation of standing chargers.

3.2 Equipment

Before installing, make sure you have the correct tools for installing the charger. In addition to safety equipment, we recommend having the following equipment on hand:

| Location preparation | Mounting of the charger | Installing the charger |
|-----------------------------|--------------------------------|-------------------------------|
| Digger/Shovel | Screwdrivers | Screwdriver |
| Level | Torx set | multi-meter |
| Measuring tape | Torque wrench | Cutting pliers |
| | Drill (for wall mounting) | Crimping pliers |
| | | Socket wrench set |
| | | Crimp connector |

3.3 Power connections

In the product spec sheet, you will find the power input specification for the charger. Please note that different power structures require different specifications. Check your product to make sure the correct power structure is considered. The charger supports a star connection and branch-sleeve connection. These connection types cannot be combined. Be aware of the limitations of each connection type and consider which is most suitable for your situation.

3.3.1 Star connection

All devices are connected to a central point (hub or distribution block). Each device has its own dedicated cable running to the central point.

Earth leakage circuit breaker connection Max.: 35mm²

Diagram:

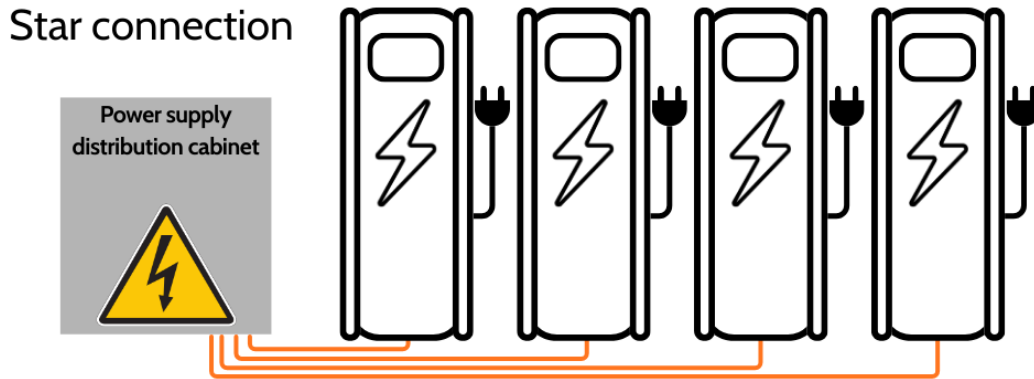

3.3.2 Branch sleeve connection

A main cable runs through, and branch connections are made using sleeves or connectors without cutting the main cable completely.

Earth leakage circuit breaker connection Max.: 35mm²

Diagram:

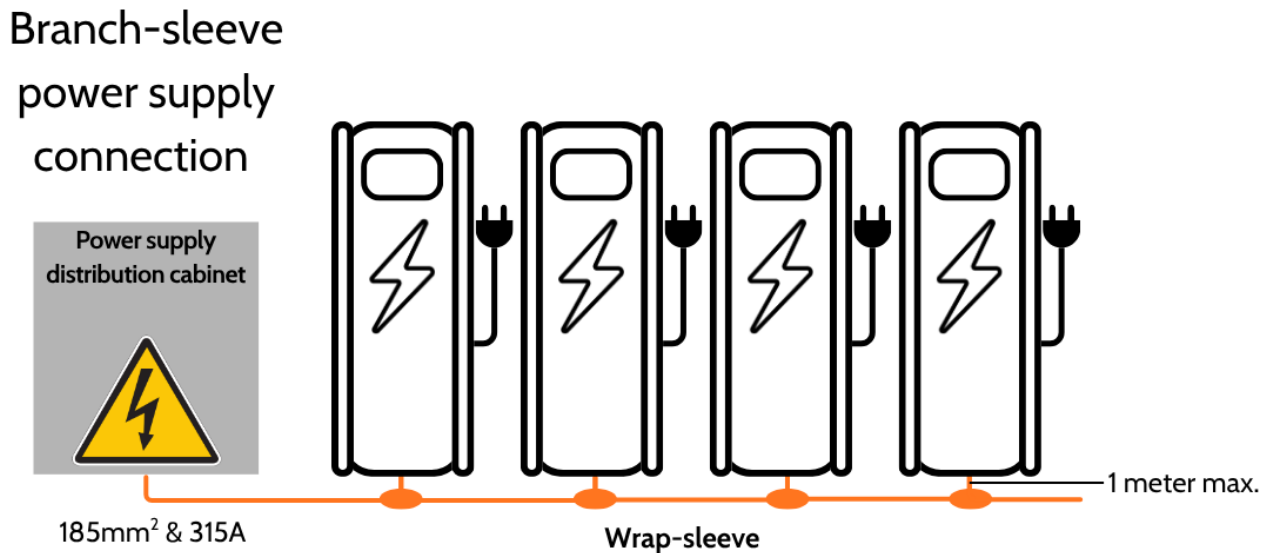

3.4 Communication infrastructure

In order to let the charger communicate with a backoffice or service, there is need for a network connection. The charger has two ways of connecting to the network, via GSM or via ethernet. Please keep in mind what connection is going to be made to ensure you have the right infrastructure in place before you begin installing.

3.4.1 GSM connection

GSM connection is the standard way of connecting to a network. For this connection to be set up, there is need for a SIM card, and there needs to be a stable antenna connection. We recommend a signal strength of at least -60dBm (see I Technical specifications).

To connect over GSM, there is need for a SIM card. Please note that switching SIM card to a different provider means that changes need to be made to the settings of the charger. Please refer to chapter 6. Configuration to learn more.



3.4.2 LAN connection

It is possible to connect the charger to a network via an ethernet cable. With this cable, you can provide a wired network connection without the need for a GSM connection and SIM. For a reliable network connection, we recommend using at least CAT5e UTP cables to connect to a network.

The cable length needs to be sufficient for reaching the connection point on the charger controller.

4. Installation

Ecotap chargers have various methods of installation, several products can be installed on the wall or on a stand.

| | |
|---|---|
|  | <p>Always follow the safety precautions and standards outlined in the Safety Instructions of this manual. Failure to do so may result in injury, damage, or improper operation.</p> |
|  | <p>Always handle the charger with care, to prevent damage to the paint, body, or components.</p> |
|  | <p>More than one person needed.</p> |

4.1 Ground mounting with stand

A charger can be mounted on a stand with or without a foundation.

| | |
|---|--|
|  | <p>Ecotap recommends using a foundation to enhance the stability and durability of the installation. The foundation is an accessory that is not included with the charger.</p> |
|---|--|

4.1.1 Stand with foundation; ground pin

Follow these steps for a safe and durable product installation:

1. Remove surface covering such as tiles
2. Dig a hole of 40cm by 25cm and 70cm deep
3. Manoeuvre the cable to the right position
4. Place the stand with ground pin in the correct orientation
5. Feed the cable through the stand
 - a. Keep enough length to reach the charger through the stand
6. Add cement and water, and mix it in the hole
7. Make sure the foundation is level
8. Fill the remains of the hole with sand/dirt.
9. Replace the surface covering
10. Remove the mounting plate on the rear of the charger

11. Remove the mounting brackets that were pre-installed on the charger

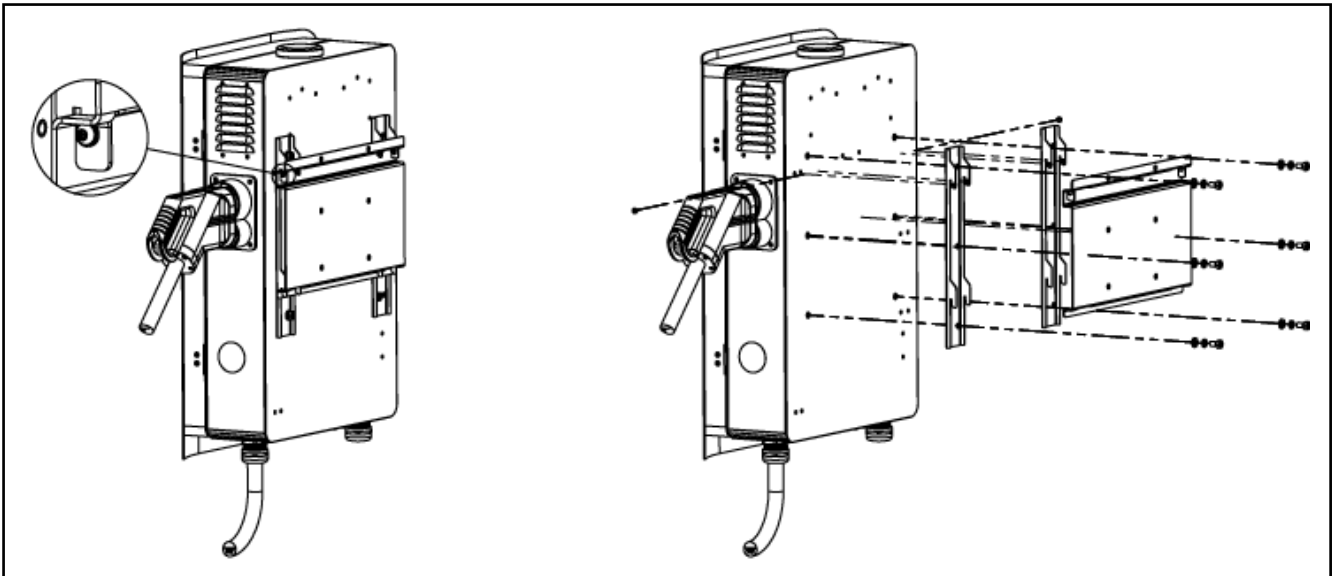

12. Mount charger on stand

- a. 6 × Torx screws from the back of the stand into the charger

13. Cap the openings for the screws in the rear of the Stand

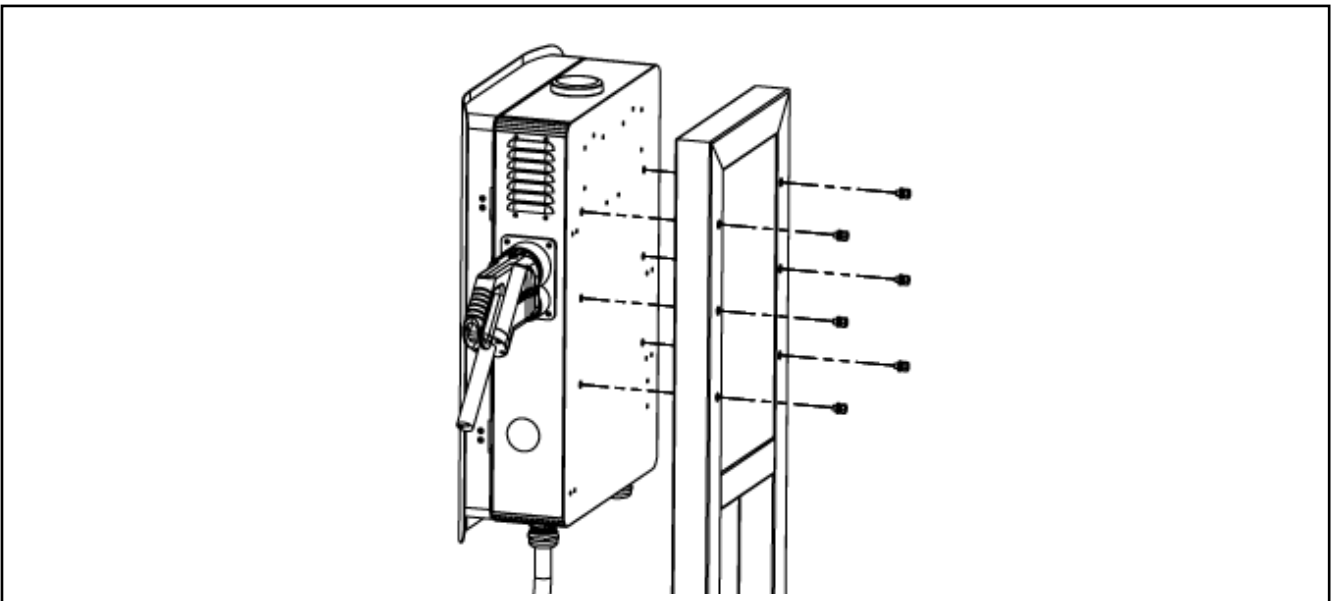

14. Open the charger

- a. 2 × security-Torx t35 screws on left side

15. Feed the cable through the stand into the charger

16. Attach the strain relief

17. Check if the charger is fully stable.

4.1.2 Stand without foundation; Baseplate

Chargers can be installed on a baseplate instead of with a foundation. This is only possible for concrete surfaces, where the installation does not easily damage or crack the ground surface. Follow these steps for a safe and durable product installation:

1. Drill holes in ground surface corresponding to the baseplate
2. Feed the cable through the stand (if necessary)
3. Bolt the stand to the ground surface
4. Make sure the stand is level
5. Remove the mounting plate on the rear of the charger
 - a. 2 × t20 Torx
6. Remove the mounting brackets that were pre-installed on the charger
 - a. 6 × Phillips screws

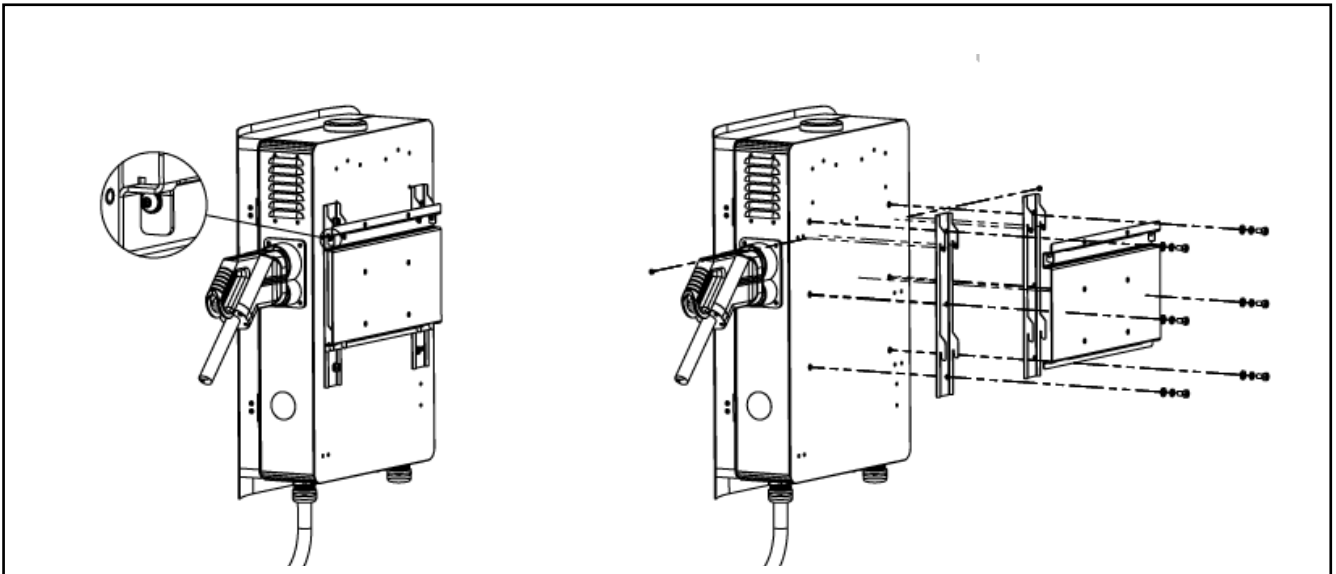

7. Mount charger on stand
 - a. 6 × Phillips screws from the back of the stand into the charger
8. Cap the openings for the screws in the rear of the Stand
9. Open the charger
 - a. 2 × security-Torx t35 screws on left side

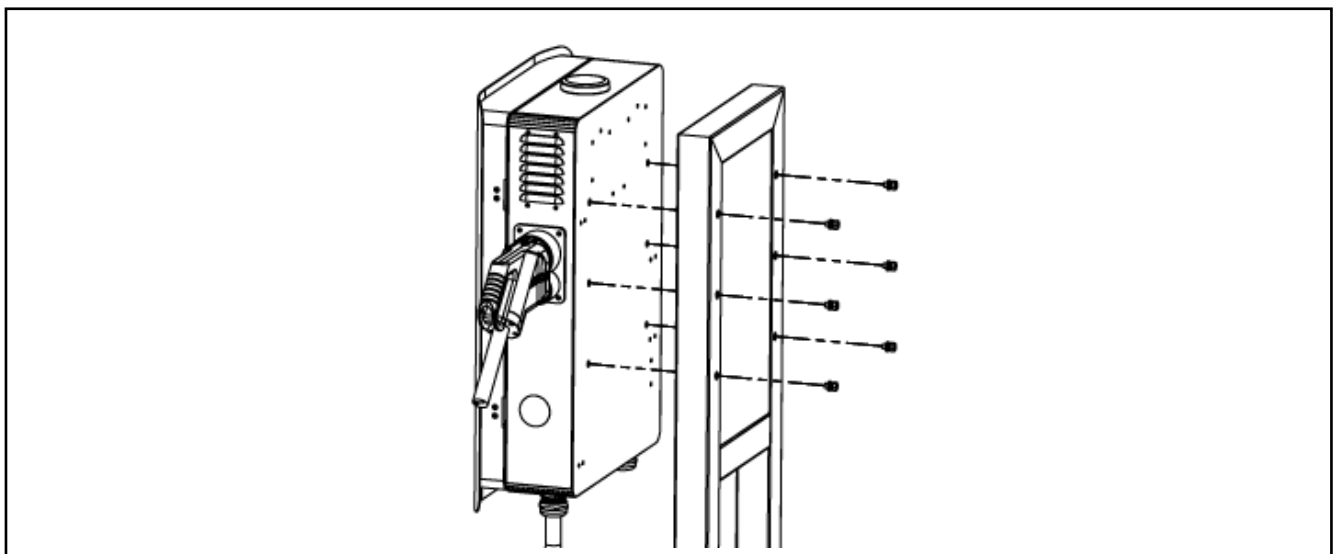

10. Feed the cable through the stand into the charger
11. Attach the strain relief
12. Check if the charger is fully stable.

4.2 Wall mounting

Follow these steps for a safe and durable product installation:

1. Determine the desired height of the charger
 - a. Ecotap recommends the height compliant with the EU Accessibility Act to ensure ergonomic access for all. Read more on commission.europa.eu.
2. Remove the mounting plate from rear of the charger
 - a. 2 × t20 Torx

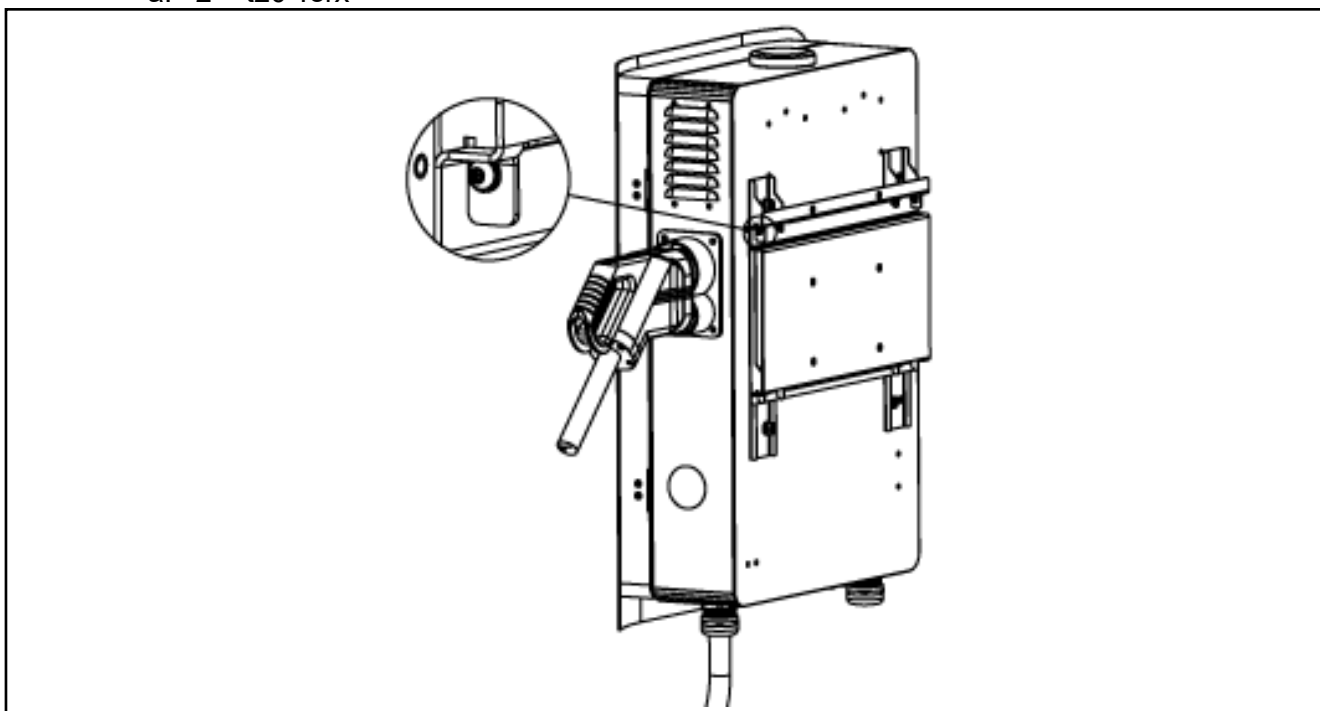

3. Drill holes in the wall corresponding to the mounting plate (See Appendix V Drill instructions mounting plate)

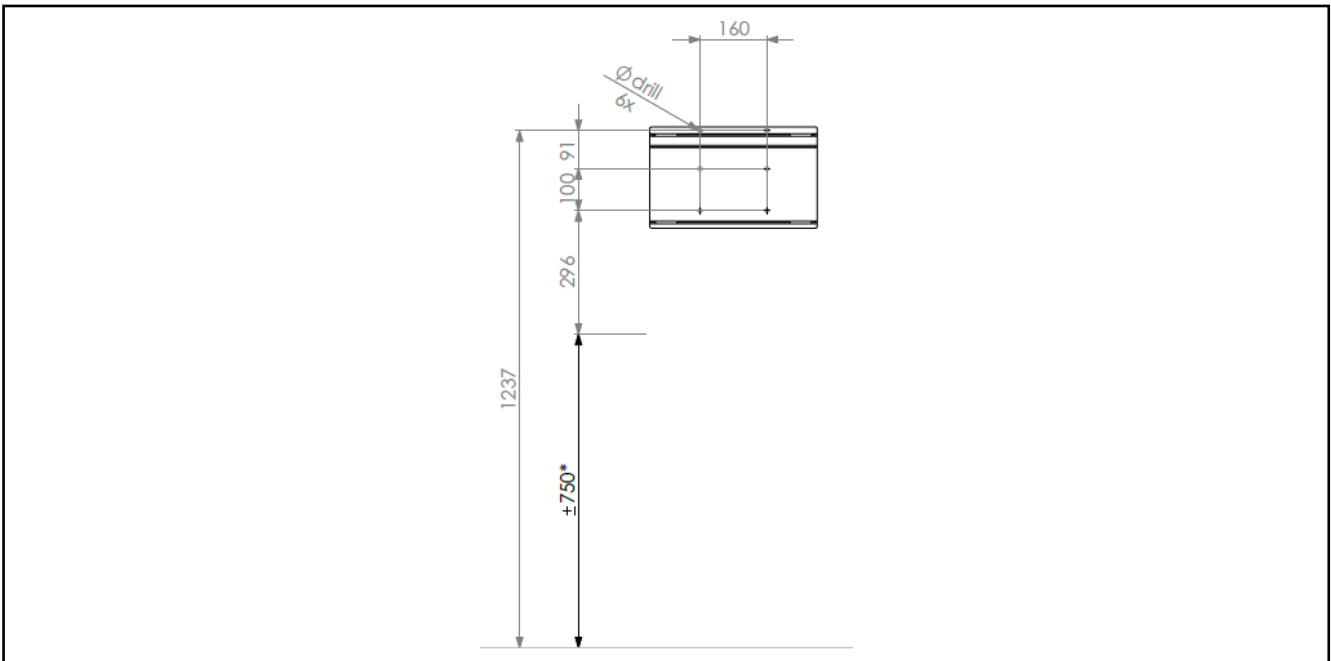

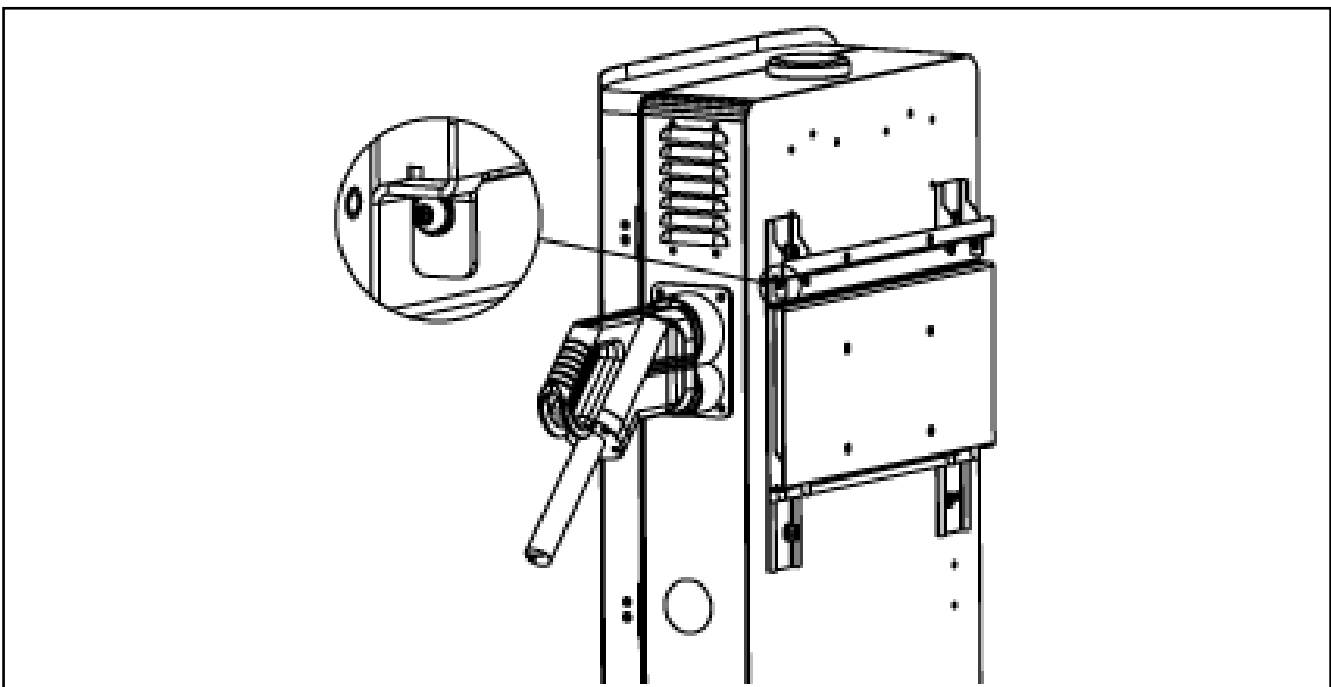

4. Install the mounting plate on the wall
 - a. 6 × Phillips screws
5. Place the charger on the mounting plate
6. Secure the charger to the mounting plate



7. Open the charger
 - a. 2 × security-Torx t35 screws on left side
8. Wire the cable into the charger
9. Attach the strain relief
10. Check if the charger is fully stable.

4.3 Electrical installation

| | |
|---|---|
|  | <p>Always follow the safety precautions and standards outlined in the Safety Instructions of this manual and work according to NEN3140. Failure to do so may result in injury, damage, or improper operation.</p> |
|  | <p>Wear insulated gloves when working with electrical wires.</p> |

All wiring connections must be made according to NEN1010/EU/35

1. Strip the cables
2. Mount the cable lugs
3. Connect the cables in the correct order:
 - a. Ground
 - b. Neutral
 - c. L1, L2, L3
4. Turn on the charger.
 - a. Switch on earth leakage circuit breaker
 - b. Test earth leakage circuit breaker
 - c. Switch on earth leakage circuit breaker
 - d. Switch on Miniature Circuit Breaker

Wait approximately 5 minutes for the green charger LED to turn on. This means the charger is online.

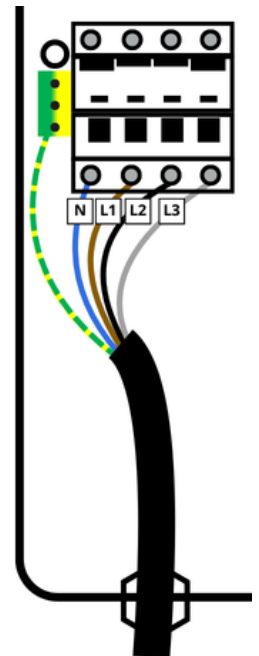

5. Commissioning

5.1 Initial startup

After you power the charger for the first time, it will run through a normal startup sequence.

- The charger begins booting, and the red LED and the display will show that the system is starting.
- The first startup can take longer than usual because the charger is setting up its internet connection.

Once the green LED turns on and the display shows the main start screen, the charger has finished its commissioning and is ready for use.

5.2 Activating charger

All chargers that require charging management need to be activated in the backoffice. The activation method depends on the chosen backend/CPO. Chargers can be activated via Ecosphere, LMS Ecotap or a third-party backend.

| | |
|--|--|
|  | <p>Activation can take up to two working days. Without activation, an installed charger cannot be tested.</p> <p>Chargers can be activated prior to installation, so they can be tested right after installation.</p> |
|--|--|

Have this information ready:

- Ecotap customer number (customer number of charging station owner)
- Controller number (on controller)
- Intended backend/CPO (e.g., LMS Ecotap or a third-party)
- Installation address
- Technical installation details (e.g., grid-plaza, load balancer, etc.)

Charger must be powered on and network ready (LAN/4G).

For the full instruction, go to ecotap.nl/activation, or scan the QR code inside the charger.



5.3 Testing charger



All chargers must be tested after installation. AC and DC chargers can be tested with an electric vehicle or with testing equipment. Ecotap recommends testing with an electric vehicle.

Testing with an electric vehicle

1. Plug the cable into the vehicle.
2. Start the charging session. (See 7. Charging methods)
3. Let it charge for a minute.
4. End the charging session.

During the testing period, the car should start charging, the charger should indicate that the session is working with a blue LED and/or an indication on the display. When ending the session, the LED should go back to green.

Testing with testing equipment

To test with an EV charger testing device, follow the instructions provided with the testing device.

6. Configuration

To configure the charger, you possibly need to change a few key settings.

1. Connect the ECC controller to your laptop with a USB-C cable.
2. Open a web browser on the laptop and go to 192.168.120.1
3. Login using credentials.
4. The charger interface can be used to check settings, configure the charger and more.
5. The charger is delivered with standard settings out of the box, be sure to check and adjust if necessary.

| | |
|---|--|
|  | <p>Default credentials: Login: service Password: service1</p> <p>It is important to remember the login credentials if they have been changed, because there is no password recovery available.</p> |
|---|--|

A number of settings must be configured differently when the setup is non-default, such as a setup with a load balancer, an Energy Management System (EMS), or a plaza-grid setup.

Refer to the relevant guides on ecotap.zendesk.com.

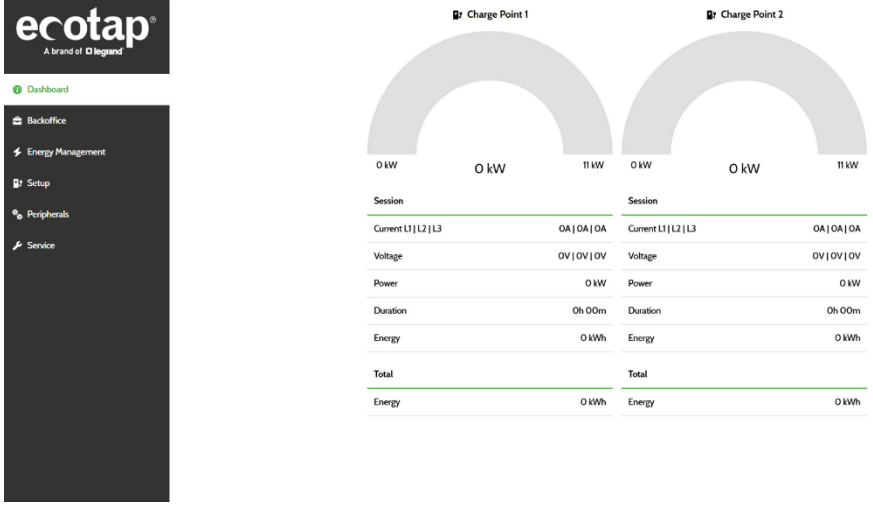

| <h3>Dashboard</h3> <p>This tab shows the status of the charger and charging session.</p> |  <table border="1"><thead><tr><th colspan="2">Charge Point 1</th><th colspan="2">Charge Point 2</th></tr></thead><tbody><tr><td>0 kW</td><td>0 kW</td><td>0 kW</td><td>0 kW</td></tr><tr><td>11 kW</td><td>11 kW</td><td>11 kW</td><td>11 kW</td></tr><tr><td colspan="2">Session</td><td colspan="2">Session</td></tr><tr><td>Current L1 L2 L3</td><td>0A 0A 0A</td><td>Current L1 L2 L3</td><td>0A 0A 0A</td></tr><tr><td>Voltage</td><td>0V 0V 0V</td><td>Voltage</td><td>0V 0V 0V</td></tr><tr><td>Power</td><td>0 kW</td><td>Power</td><td>0 kW</td></tr><tr><td>Duration</td><td>0h 00m</td><td>Duration</td><td>0h 00m</td></tr><tr><td>Energy</td><td>0 kWh</td><td>Energy</td><td>0 kWh</td></tr><tr><td colspan="2">Total</td><td colspan="2">Total</td></tr><tr><td>Energy</td><td>0 kWh</td><td>Energy</td><td>0 kWh</td></tr></tbody></table> | Charge Point 1 | | Charge Point 2 | | 0 kW | 0 kW | 0 kW | 0 kW | 11 kW | 11 kW | 11 kW | 11 kW | Session | | Session | | Current L1 L2 L3 | 0A 0A 0A | Current L1 L2 L3 | 0A 0A 0A | Voltage | 0V 0V 0V | Voltage | 0V 0V 0V | Power | 0 kW | Power | 0 kW | Duration | 0h 00m | Duration | 0h 00m | Energy | 0 kWh | Energy | 0 kWh | Total | | Total | | Energy | 0 kWh | Energy | 0 kWh |
|--|--|----------------------|--------------|----------------|--|------|------|------|------|-------|-------|-------|-------|---------|--|---------|--|----------------------|--------------|----------------------|--------------|---------|--------------|---------|--------------|-------|------|-------|------|----------|--------|----------|--------|--------|-------|--------|-------|-------|--|-------|--|--------|-------|--------|-------|
| Charge Point 1 | | Charge Point 2 | | | | | | | | | | | | | | | | | | | | | | | | | | | | | | | | | | | | | | | | | | | |
| 0 kW | 0 kW | 0 kW | 0 kW | | | | | | | | | | | | | | | | | | | | | | | | | | | | | | | | | | | | | | | | | | |
| 11 kW | 11 kW | 11 kW | 11 kW | | | | | | | | | | | | | | | | | | | | | | | | | | | | | | | | | | | | | | | | | | |
| Session | | Session | | | | | | | | | | | | | | | | | | | | | | | | | | | | | | | | | | | | | | | | | | | |
| Current L1 L2 L3 | 0A 0A 0A | Current L1 L2 L3 | 0A 0A 0A | | | | | | | | | | | | | | | | | | | | | | | | | | | | | | | | | | | | | | | | | | |
| Voltage | 0V 0V 0V | Voltage | 0V 0V 0V | | | | | | | | | | | | | | | | | | | | | | | | | | | | | | | | | | | | | | | | | | |
| Power | 0 kW | Power | 0 kW | | | | | | | | | | | | | | | | | | | | | | | | | | | | | | | | | | | | | | | | | | |
| Duration | 0h 00m | Duration | 0h 00m | | | | | | | | | | | | | | | | | | | | | | | | | | | | | | | | | | | | | | | | | | |
| Energy | 0 kWh | Energy | 0 kWh | | | | | | | | | | | | | | | | | | | | | | | | | | | | | | | | | | | | | | | | | | |
| Total | | Total | | | | | | | | | | | | | | | | | | | | | | | | | | | | | | | | | | | | | | | | | | | |
| Energy | 0 kWh | Energy | 0 kWh | | | | | | | | | | | | | | | | | | | | | | | | | | | | | | | | | | | | | | | | | | |

Backoffice

This tab shows all relevant information for the backoffice.

Connection

Settings for communication method and chosen backend.

OCPP Backends

New backend connections can be added here.

SIM Cards

New APN connections can be added here.

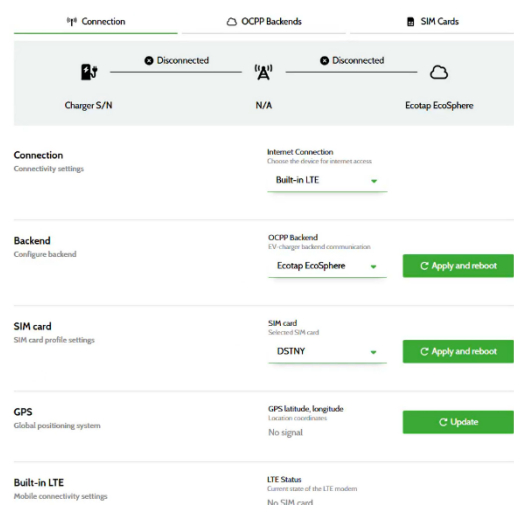
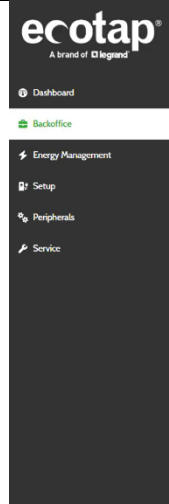

Energy Management

Power related settings can be changed on this tab. This can be done for the charger as a whole or per specific charge point.

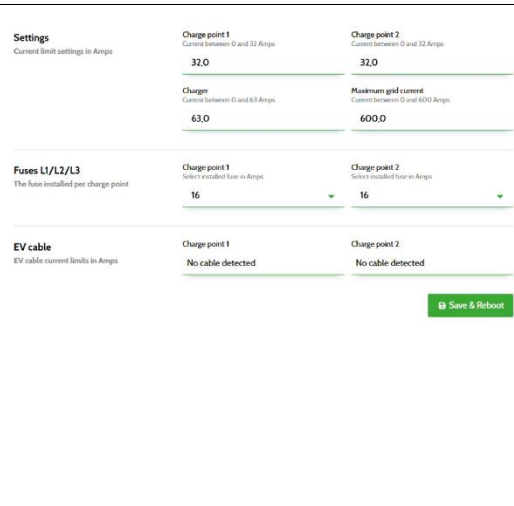
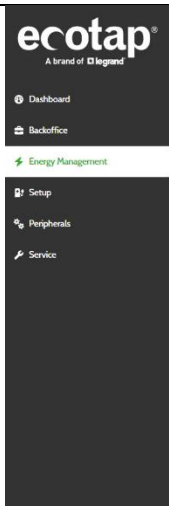

Setup

Charger setup

This tab can be used to setup technical specifications; these settings are specific for the components inside the charger.

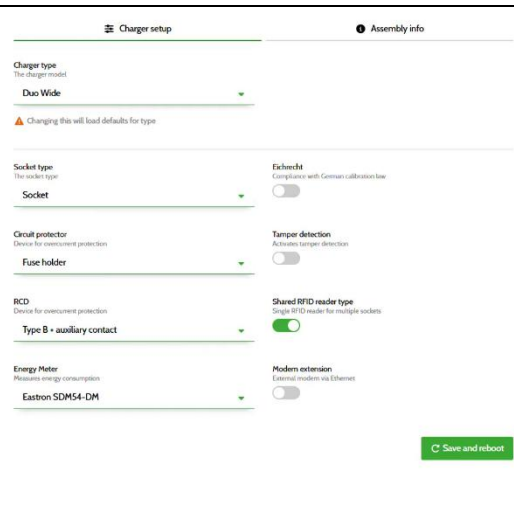
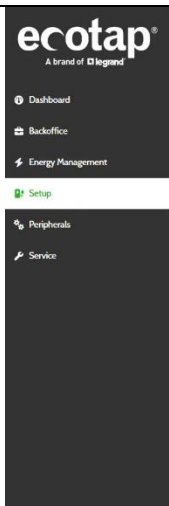

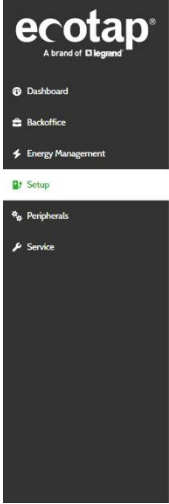
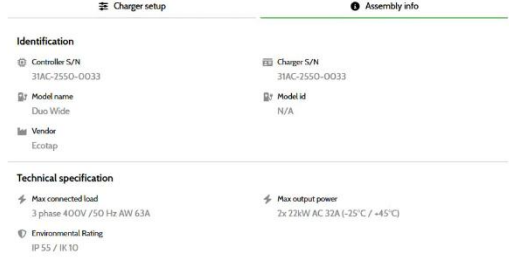
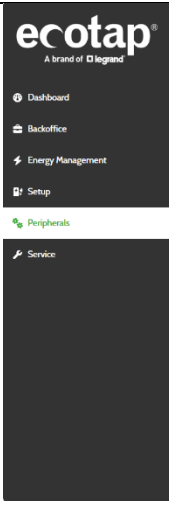
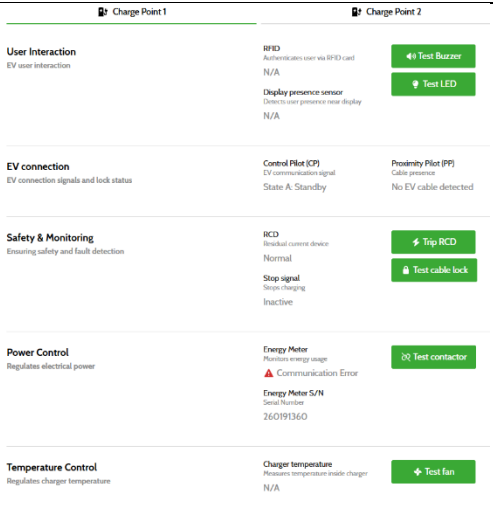
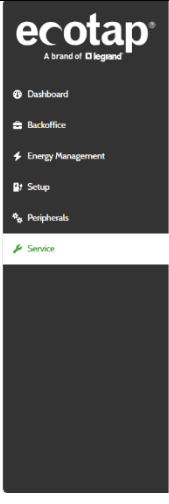
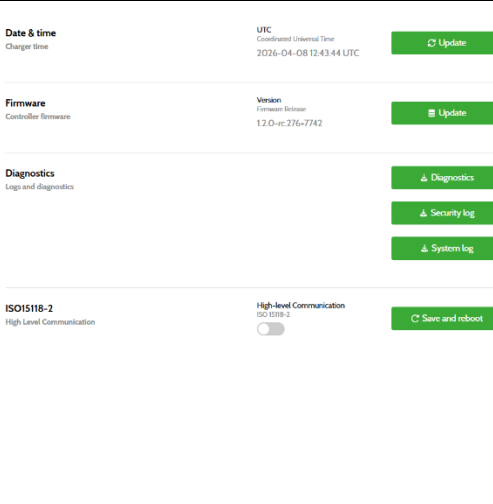
| | | |
|---|---|--|
| <p>Setup <i>Assembly info</i></p> <p>This tab shows the product identification information and several technical specifications.</p> |  |  |
| <p>Peripherals</p> <p>This tab shows the status of several aspects of the charger.</p> <p>Communication- and electrical components can be tested per charge point.</p> |  |  |
| <p>Service</p> <p>Firmware can be updated on this tab.</p> <p>Important logs necessary for service can be downloaded here.</p> <p>The High-Level Communication switch enables ISO 15118-2 communication.</p> |  |  |

Refer to the complete Maintenance interface guide for more information.

7. Charging methods

Depending on the CPO and charger type, there are several ways of starting and ending charging sessions. DC30 Nuvia supports the following:

- RFID
- ISO15118 Plug&Charge
- Dynamic QR-code

7.1 RFID

Every charger includes an RFID reader. Simply use your charging tag to start and stop a charging session quickly and easily.

- Starting a charging session
 - Insert cable to car & charger
 - Scan tag
- Ending a charging session
 - Scan tag
 - Remove cable from car & charger



7.2 Plug & Charge ISO15118*

Your car acts as the identifier. Just plug in, and charging begins automatically, no tag or extra steps needed.

- Starting a charging session
 - Insert cable to car & charger
 - Session starts
- Ending a charging session
 - End session from the vehicle interface
 - Remove cable from car & charger

**High-Level communication must be enabled via Maintenance Interface (6. Configuration). The vehicle must also support the ISO15118 Plug & Charge protocol.*

7.3 Dynamic QR-Code*

A charging session can be started with a unique QR code on the charger's screen. Scan it to access a secure page, enter payment details, and start charging. This method is safer than static QR codes, reducing fraud risk.

Pricing & charging power can be seen in your online environment after scanning, how this is shown is dependent on the CPO.

- Starting a charging session
 - Insert cable to car & charger
 - Scan QR code on charger
 - Start session from your mobile phone
- Ending a charging session
 - End session from the online environment or in the vehicle interface.
 - Remove cable from car & charger



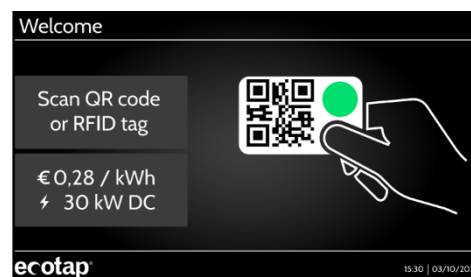

**The availability of using a dynamic QR code depends on the chosen backend.*



8. Care and maintenance

Regular maintenance keeps your charger safe, reliable, and efficient.

- Extends lifespan by preventing wear and damage.
- Ensures safety by avoiding water ingress and loose connections.
- Maintains performance.

| | | |
|--|--|---|
|  | <p>For detailed steps and safety instructions, always refer to the complete maintenance guide for your charger on ecotap.nl/downloads.</p> |  |
|  | <p>Disconnect power and check voltages to make sure the charger is not live.</p> | |
|  | <p>For the DC30 it is critical to switch off the external power supply because of potential exposure to high voltage.</p> | |

General Maintenance for All Chargers

Perform these checks regularly, according to the maintenance guide:

- Exterior Cleaning: Wipe the outside with water and mild cleaner using a soft cloth. Avoid high-pressure water.
- Interior Cleaning: Remove dust, dirt, and insects inside the charger.
- Check Seals & Rubbers: Inspect sealing rubbers and antenna seals for cracks or gaps.
- Inspect for Water & Corrosion: Look for leaks or rust inside and outside.
- Ground Connection: Ensure earth connections are secure.
- Functional Test: Run a full charging test at least once a year.

9. Troubleshooting & Support

9.1 Requesting support

Support during installation

Ecotap offers support to installers. Support requests can be submitted via: ecotap.zendesk.com.

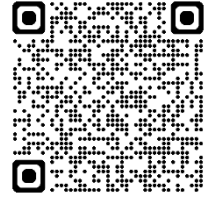

If you expect to require assistance during installation, please **request support in advance**. When in doubt, it is advisable to request support beforehand, as Ecotap cannot provide ad-hoc installation assistance. If you do not need support, you are free to cancel.

Support with malfunctioning chargers

If you currently have a charging installation which has an issue, reach out to your CPO if you have one. If the problem is not solved, contact the appropriate service team through ecotap.nl/helpdesk.







Other support requests

Read through the frequently asked questions on ecotap.zendesk.com.

If you cannot find the solution there, contact us through ecotap.nl/helpdesk.



9.2 Charger status and LED indications

| | Continuous | Flashing |
|--|-----------------------------------|--|
| Green  | Ready to use. | Four possible scenarios: 1 EV plugged in, waiting for user action to proceed. 2 Waiting for EV to be plugged in. 3 Analysis under progress after any user action. 4 EV fully charged, waiting for user to end session. |
| Red  | Error without vehicle plugged in. | Three possible scenarios: 1 Error with vehicle plugged in. 2 Authentication failed. 3 Payment failed. |
| Blue  | Charging. | - |
| Off  | No power. | - |

10. Legal

10.1 CE Declaration

Ecotap B.V. hereby declares that the DC30 Nuvia charging station complies with the essential requirements of the EMC 2014/30/EU, LVD 2014/35/EU, RoHS 2011/65/EU and RED 2014/53/EU directives.

See the full declaration on ecotap.nl.



10.2 WEEE

Ecotap products comply with the requirements of the WEEE Directive (2012/19/EU).

Electrical and electronic equipment contains materials and components that can be harmful to people and the environment if they are not disposed of properly. Products marked with the crossed-out wheeled bin symbol fall under this category. This symbol means the equipment must be collected separately and may not be thrown away with regular household waste.

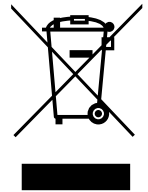

Please contact your local authority for information on available collection or recycling programs. They can direct you to designated recycling centres or collection points where waste electrical and electronic equipment can be safely disposed of.

10.3 Warranty

Ecotap products are covered by a standard warranty period as specified in the Ecotap general terms and conditions, unless stated otherwise. All warranty provisions, limitations, and conditions are governed by the Ecotap general terms and conditions, which can be found on ecotap.nl.



10.4 Returns

Product returns are only accepted when approved in advance by Ecotap. Returned items must meet the applicable return conditions as outlined in the Ecotap General Terms and Conditions. All requirements, and limitations for returns are governed by the Ecotap General Terms and Conditions, which can be found on ecotap.nl.



11. Appendix

I Technical specifications

| GENERAL CHARACTERISTICS | |
|--|--|
| Reference number | 840132001 / 840132003 / 840132004 / 840132005 / 840132007 / 840132008 |
| Accessories | 669992 / 669993 |
| Dimension H x W x D (mm) | 710 mm x 460 mm x 200 mm |
| Casing material | Steel 2,2 mm |
| Standard colour | Body: Ral 7011 / Cover: Ral 9016 |
| Surface treatment | Anti-corrosion (KTL) and powder coating |
| Weight (kg) | 60 kg |
| Number of charging points | 1 |
| Cable | Type 2 CCS |
| Display | Display: 7", IPS, Full colour, 1024 x 600 px |
| ELECTRICAL CHARACTERISTICS | |
| AC input voltage | 3 x 400VAC + N \pm 10% |
| AC input current and power (line-side) | 45A at 30 kW DC output power |
| AC input Frequency (fn) | 50Hz |
| DC output power range | 1 - 30 kW |
| DC output voltage range | 200 - 1000 Vdc |
| DC output current range | 0 - 100A |
| DC output voltage stabilized accuracy | $\leq \pm 0.5\%$ |
| DC output current stabilized accuracy | $\leq \pm 1\%$ |
| Efficiency | > 95% @ Max. power |
| THDi (Total harmonic distortion) | < 5% (load 50% to 100%) |
| Power factor | > 0.99 (load 100%); > 0.98 (load 50% to 100%) |
| Mains type | TN-C, TN-S, TN-C-S or TT |

| | |
|--|---|
| Impulse voltage (Uimp) | 4kV |
| Insulation voltage (Ui) | 230V single-phase 500V three-phase |
| Integrated protection system | RCD 63A 30mA Type B |
| Conditional short-circuit | Not included |
| Allowable thermal stress in Short Circuit | 16 000 A ² s |
| Integrated surge protection | Not included |
| Standby consumption (W) | ≤ 30W |
| Connection to the mains | Phase/Neutral/Earth, rigid cable or soft cable with ferule, 2.5 to 16 mm ² , screw terminals H07 V R/U |
| Type of load | Mode 4 charging terminal |
| Vehicle connection Mode 4 attached cable connector | 3,5m CCS cable, 150A: 840132001 / 840132003 / 840132004 7,5m CCS cable, 150A: 840132005 / 840132007 / 840132008 Use of extension and/or adapters is prohibited. |
| AC meter | Not included |
| DC meter | DC MID certified meter included: 840132003 / 840132004 / 840132007 / 840132008 |
| Backoffice protocol | OCPP 1.6, 2.0.1 and OCPP 2.1-ready |
| Positioning | GPS |
| Connectivity Ethernet | RJ45 connector |
| Connectivity GSM | 2G/3G/4G LTE Cat M |
| ENVIRONMENT | |
| Operating temperature | -25°C / +50°C |
| Storage temperature | -25°C / + 80°C |
| Relative humidity | 0 to 95% without condensation |
| Protection rating | IP55 (IEC 60529) |
| Vandalism resistance | IK10 (EN62262), includes display |
| Noise level | < 68 dB at 1m at 20° C, at full charging |

| | |
|--|---|
| Product | IEC 61851-1, IEC TS 61439-7 (AEVCS), IEC 61851-23, IEC 62477-1, IEC 61439-1 |
| DC standard protocol (communications with the vehicle) | CCS2: IEC 61851-23 / DIN SPEC 70121 |
| Installation | Interior or exterior, limited access zone, intended for use by ordinary persons (DBO), assembly in cabinet (wall mounted), Pollution Degree 3, TN-C, TN-S, TN-C-S or TT compatible earthing system. In the event of an IT earthing system, this can be changed locally by adding an isolating transformer. |
| Electrical safety | Class 1 IEC 61140 |
| Eichrecht conform | No |
| COMPLIANCY | |
| European standards | EMC 2014/30/EU, LVD 2014/35/EU, RoHS 2011/65/EU and RED 2014/53/EU |
| Radio technology type | GSM 2G/3G/4G, GPRS, RFID |
| Suitable charging cards | Mifare, Ntag and iCODE SLI cards |

II Product dimensions

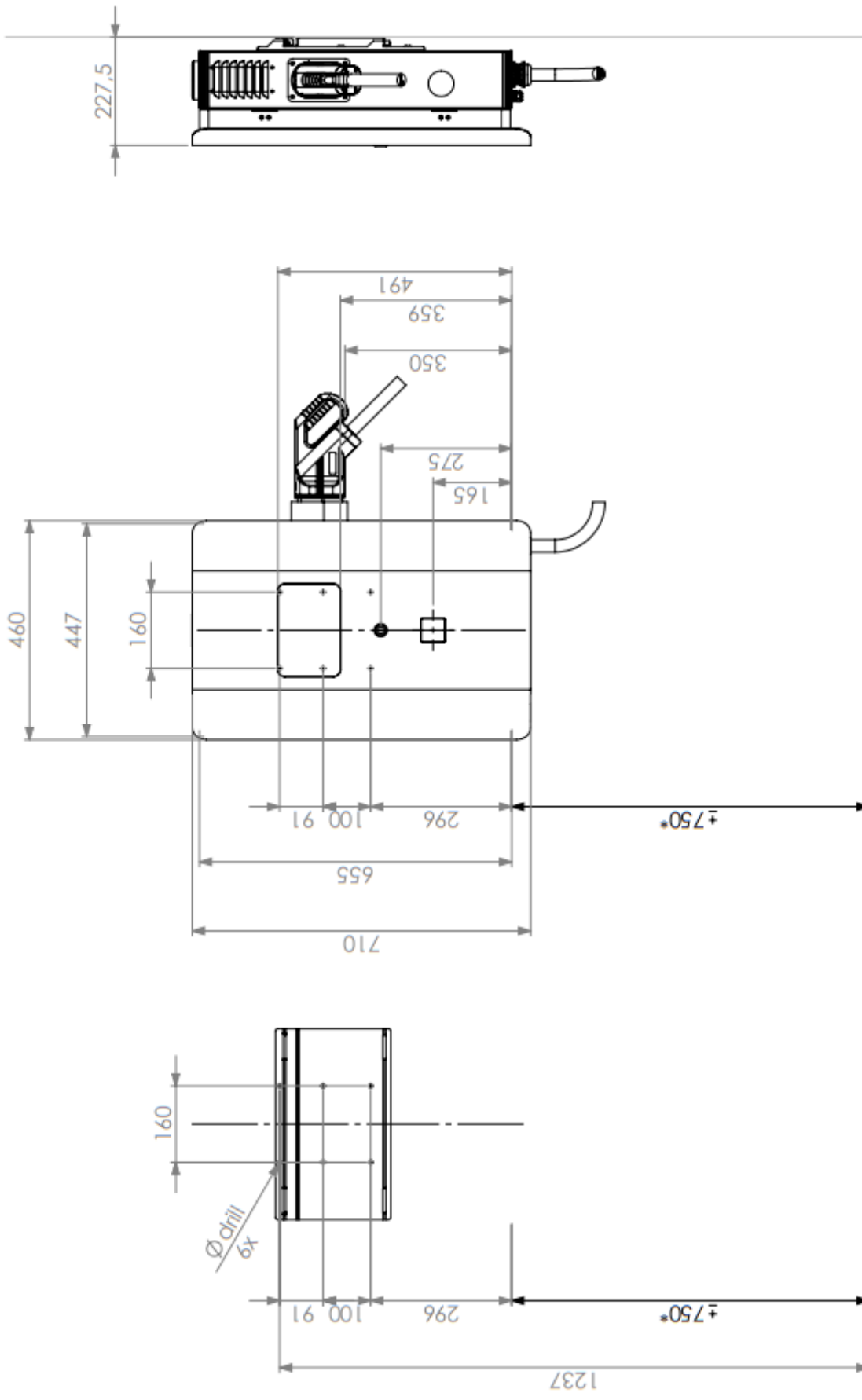

III Dimensions Stand

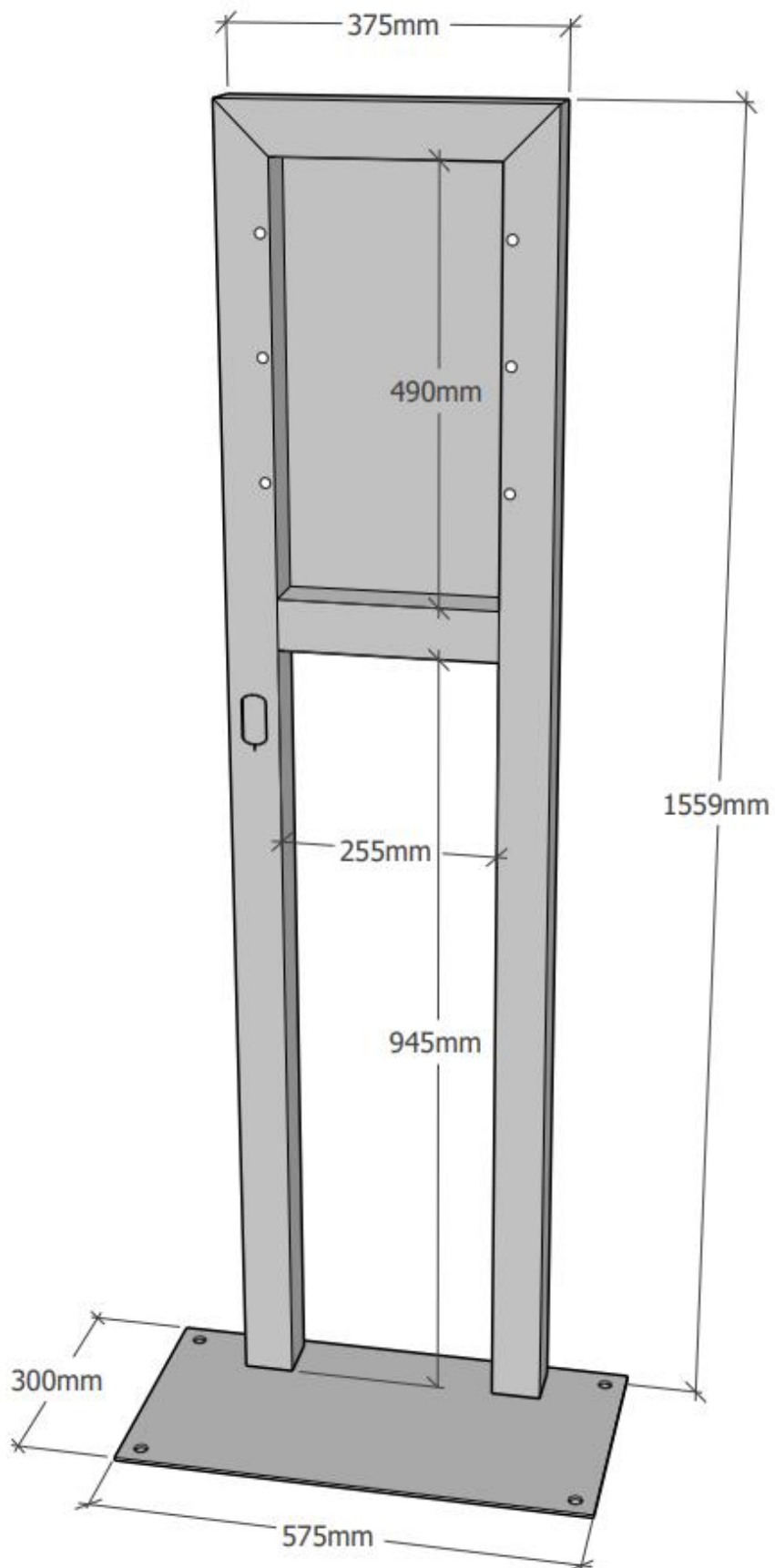

IV Dimensions Stand baseplate

In mm

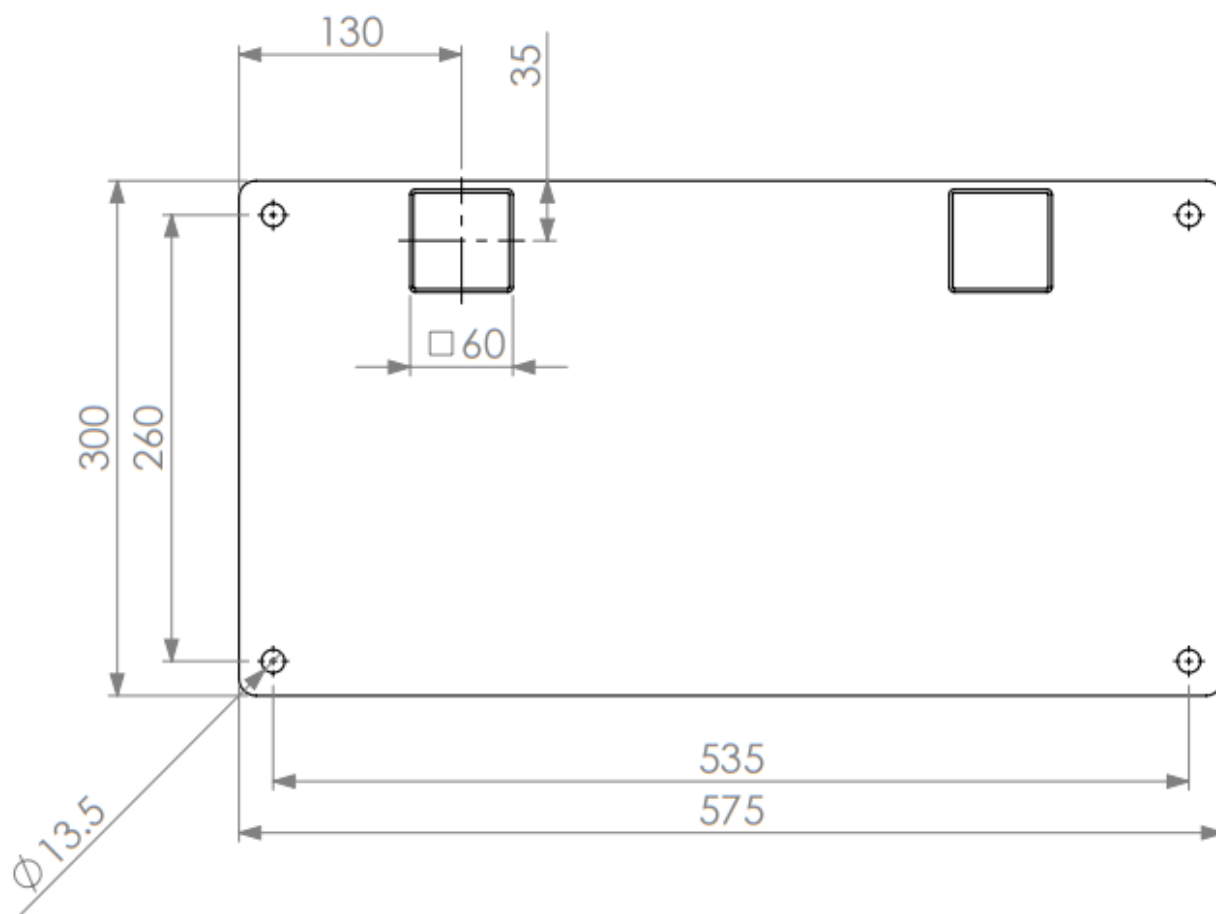

V Drill instructions mounting plate

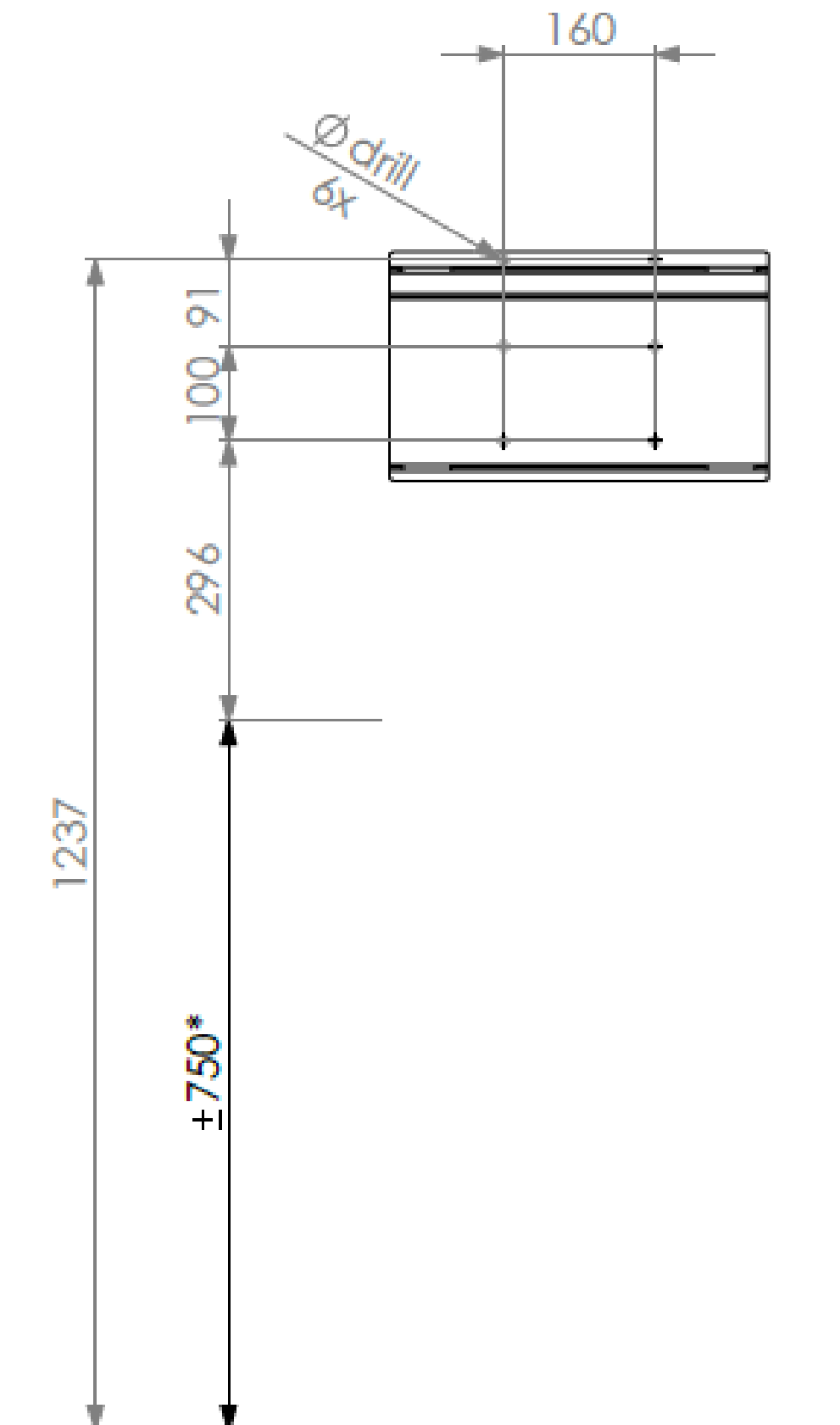

ecotap[®]
A brand of  **legrand**[™]

Ecotap B.V.
Kruisbroeksestraat 23
5281 RV Boxtel
+31(0) 411 210 210
info@ecotap.nl
